

The CHIC Series is a low-profile, compact, LED illuminated combination emergency unit/exit sign for the City of Chicago that operates for a minimum of 90 minutes during a power outage. The CHIC Series features a Lithium Ion class battery coupled with durable 20 gauge steel construction with a UL 924 compliant single-face EXIT glass panel in an attractive styling for ceiling, end, pendant or wall mount applications. A full range of alternative glass panels are available as accessories.

**FEATURES**

- Suitable for City of Chicago
- UL 924 Listed for Damp Locations
- Universal input voltage from 120VAC to 277VAC, 50/60Hz
- Includes all necessary hardware for ceiling, end or wall mounting
- Constructed of rugged 20 gauge steel with heat-tempered, impact-resistant translucent glass panels

**SPECIFICATIONS**

**Illumination:** Long-life, high-intensity, white LEDs for the sign; Two long-life, high-intensity LED lamp heads with (3) LEDs per lamp head. Two 2.85W lamp heads provide 396 lumens each, rotates vertically 0°- 90° from nadir and rotates horizontally 0°- 350°. Lamp heads may be mounted on top or on side of sign

**Housing:** 20 Gauge steel with a white powder coated finish. Glass panels are heat-tempered, impact- and scratch-resistant with red silk-screened lettering on white finish

**Battery:** Maintenance-free LiFePO4 battery

**Electrical Input:** Universal input voltage - 120 to 277VAC, 50/60Hz

**Operating Temp:** 5°C to 45°C (41°F to 113°F)

**Run Time:** UL Listed 90 minute emergency run time, 24 hour recharge time

**Electrical:** Low voltage disconnect eliminates deep discharge, brownout, short circuit and overload protection

**Legend:** Fully illuminated red 6" characters with 3/4" stroke; comes standard with single-face CHIAXC-PANEL-3 (no arrows)

**Mounting:** Pendant (by others), ceiling, end or wall mount (canopy included)

**Finishes:** White

**Certifications:** UL 924 Damp Location Listed, meets or exceeds City of Chicago, NEC requirements and NFPA 101

**Warranty:** Any component that fails due to a manufacturing defect is guaranteed for five years with a separate five year prorated warranty on the battery. The warranty does not cover physical damage, abuse or instances of uncontrollable natural forces. See the full Exitronix warranty document for detailed information (Terms and Conditions apply)

Model: \_\_\_\_\_ Date: \_\_\_\_\_  
 Accessories: \_\_\_\_\_  
 Job Name: \_\_\_\_\_ Type: \_\_\_\_\_

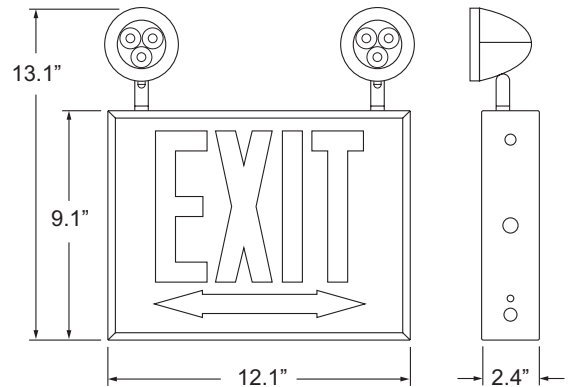

**ORDERING INFORMATION Example: CHIC**

Series	Single-face Panel Accessories <sup>2,3,4</sup>	Double-face Panel Accessories <sup>2,3,5</sup>
CHIC <sup>1</sup>	CHIAXC-PANEL-3 = EXIT (include with fixture)	CHIAXC-PANEL-18 = EXIT
	CHIAXC-PANEL-6 = EXIT▶	CHIAXC-PANEL-21 = ◀EXIT, EXIT▶
<b>Notes</b>	CHIAXC-PANEL-9 = ◀EXIT	CHIAXC-PANEL-24 = ◀EXIT▶
<sup>1</sup> Comes standard with single face CHIAXC-PANEL-3	CHIAXC-PANEL-12 = ◀EXIT▶	CHIAXC-PANEL-17 = STAIRS
<sup>2</sup> All panels supplied with red letters on a white background	CHIAXC-PANEL-2 = STAIRS	CHIAXC-PANEL-20 = ◀STAIRS, STAIRS▶
<sup>3</sup> Order as separate line item, field installed	CHIAXC-PANEL-5 = STAIRS▶	
<sup>4</sup> One faceplate only	CHIAXC-PANEL-8 = ◀STAIRS	
<sup>5</sup> Two faceplates		

**CONSTRUCTION**

The CHIC Series combination emergency unit/exit signs are constructed of 20 gauge steel with a white powder coated finish providing scratch and corrosion resistance. The open face glass panels are heat-tempered, impact- and scratch-resistant with red silk-screened lettering on white finish.

**ILLUMINATION**

Exit face illumination is provided by special high-intensity white indirect LEDs with an estimated life of up to 100,000 hours. The emergency lights consist of two long-life, high-intensity LED lamp heads with (3) LEDs per lamp head. Each 2.85W lamp head provides 396 lumens, rotates vertically 0°- 90° from nadir and rotates horizontally 0°- 350°. Lamp heads may be mounted on top or side of sign.

**ELECTRICAL**

**Input**

Universal input voltage - 120 to 277VAC @ 50/60Hz. Overload and short circuit protection included.

**LiFePO4 Battery**

Maintenance-free, long-life, rechargeable LiFePO4 batteries. Fully automatic, solid-state charger initiates battery charging to recharge a discharged battery within 24 hours. The internal solid-state transfer switch automatically connects the internal battery to power the LED board for a minimum of 90 minutes of illumination during the loss of utility power. An LED indicator light alerts occupant on battery condition (Steady-normal, Blinking-check battery).

**Emergency**

The CHIC Series exit will operate for a minimum of 90 minutes during a loss of power with a 24 hour maximum recharge time for the battery.

**Brownout Circuit**

Brownout circuit monitors the line voltage. As the line voltage sags and can no longer illuminate the exit sign to meet UL 924 visibility test, the emergency circuit will turn on to supply a portion or all the power to illuminate the sign for 90 minutes until line voltage is restored.

**Low Voltage Disconnect**

Low Voltage Disconnect (LVD) measures the battery terminal voltage. The LVD continuously monitors the battery terminal voltage and if it should fall below a preset voltage threshold, the LVD will disconnect the load. When the battery is recharging and voltage is raised above another preset voltage threshold, the load is automatically reconnected.

**Solid-State Transfer**

The circuit features solid-state switching for emergency lamps, eliminating concerns of damaged contact or mechanical failures associated with relays. The switching circuit detects a loss of line voltage and automatically switches to emergency mode.

**Overload and Short Circuit Protection**

The overload monitoring system is a solid state circuit which monitors the lamp load and disconnects from the battery should an overload or short circuit occur. The overload current protection eliminates the need for fuses or circuit breakers for the DC load.

**Test Button**

The test button is easy to locate and provides manual verification of the transfer circuit, battery condition and emergency lamps.

**INSTALLATION**

Installs in minutes with easy-to-read instructions and detailed diagrams. A universal knockout pattern on the rear for direct mounting to junction box and a steel canopy is provided for ceiling or end mounting. Knockouts are included on top for pendant mount. No special hardware or tools necessary. Internally housed components and battery.

**CONFORMANCE TO CODES & STANDARDS**

The CHIC Series is UL 924 Listed for Damp Locations and meets or exceeds the following: City of Chicago Fire Code, NEC requirements and NFPA 101.

**SAMPLE PHOTOMETRICS - 3' PATH OF EGRESS**

Using multiple CHIC units mounted at a typical 7.5' height delivers 62' on-center spacing with a 3' wide path of egress using 80/50/20 reflectances.

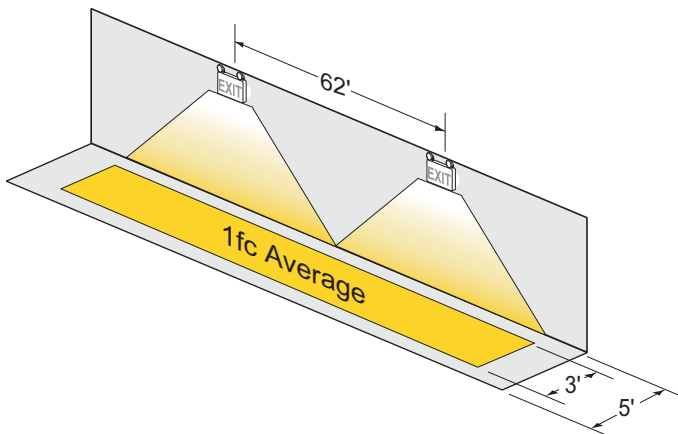

**SAMPLE PHOTOMETRICS - 6' PATH OF EGRESS**

Using multiple CHIC units mounted at a typical 7.5' height delivers 61' on-center spacing with a 6' wide path of egress using 80/50/20 reflectances.

